

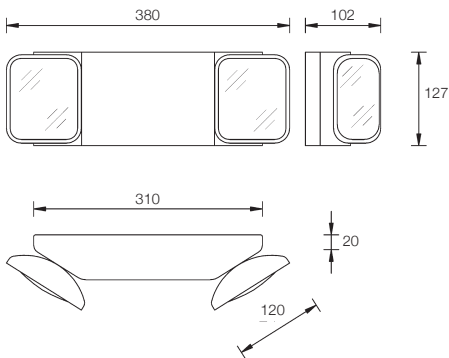

MS203



Dimension: mm NTS



Type and batch tested with
PSB PLS-LISTED LABEL

**Surface Mount
Emergency Luminaire**



**IP50
CLASS 2**

» Technical Data

- Mode of operation : Non-maintained
- Lamp : 2 x 6V 5.4W incandescent lamp
(halogen lamp also available)
- Rated duration : 2 hr and others
- Mains supply : 230 Volts, 50/60Hz
- Power consumption : 3VA
- Battery : Maintenance free 6V 7.2 AH sealed lead calcium battery
- Charge monitor : Red LED ø5mm
- Test facility : Push-off test switch
- Safety feature : Low volt cut-off preventing battery overdischarge
- Housing : Injection moulded thermoplastic ABS; UL 94V-0 flame rating, two fully adjustable glare-free square shaped heads
- Mounting : Wall or ceiling. The snap-fit design will facilitate easy installations. Easily removable mounting and knockout holes are provided
- Cable entry : ø20mm K/O hole
- Weight : 2.7kg (gross)
- Compliance : SS CP19, SS263 : Part 2, IEC 598-2-22
- Warranty : 1 year

» Ordering Guide

Please check with Sales Dept if customisation is required

| Model | Lamp (watt) | Battery type |
|-------|----------------------|---------------------|
| MS203 | 2 x 5.4 Incandescent | Sealed lead calcium |

Specifications subject to changes without prior notice