

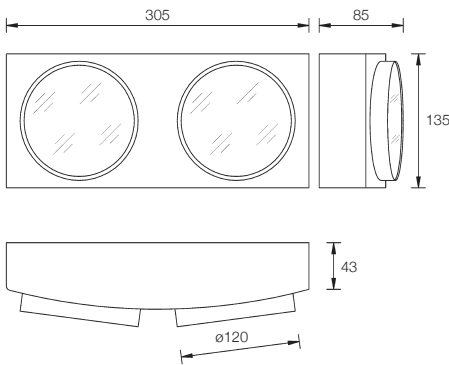

MR203L NC



Dimension: mm NTS

**High Power L.E.D**  
from LUMILEDS

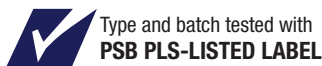

Type and batch tested with  
**PSB PLS-LISTED LABEL**

**Surface Mount**  
**Energy Efficient**  
**Emergency Luminaire**



**IP50**  
**CLASS 2**

### » Technical Data

Mode of operation	: Non-maintained
Lamp	: 2 x 1W Light Emitting Diode (LED)
Rated duration	: 2 hr and others
Mains supply	: 230 Volts, 50/60Hz
Power consumption	: 2VA
Battery	: High temp nickel cadmium
Charge monitor	: Red LED ø5mm
Test facility	: Miniature test switch
Safety feature	: Low volt cut-off preventing battery overdischarge
Housing	: Injection moulded thermoplastic ABS; UL 94V-0 flame rating, two fully adjustable glare-free round shaped heads
Mounting	: Wall or ceiling. The snap-fit design will facilitate easy installations. Easily removable mounting and knockout holes are provided
Cable entry	: ø20mm K/O hole
Weight	: 1.2kg (gross)
Compliance	: CP19, SS263 : Part 2, IEC 598-2-22
Warranty	: 1 year

### » Ordering Guide

Please check with Sales Dept if customisation is required

Model	Lamp (watt)	Battery type
MR203L NC	2 x 1 LED	Nickel cadmium

### » Key Features

- high brightness output
- low power consumption
- low maintenance
- high lumen/watt efficiency
- long lifespan

Specifications subject to changes without prior notice