

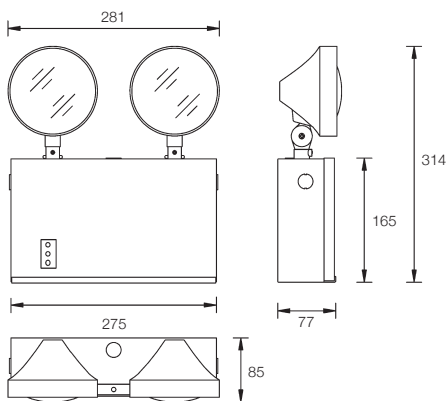

MTL/NM/L203

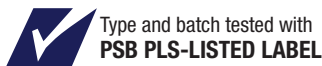

Dimension: mm NTS



**Surface Mount  
Wide Angle  
Emergency Luminaire**



**CLASS 1**

### » Technical Data

- Mode of operation : Non-maintained
- Lamp : 2 x 3W Light Emitting Diode (LED)
- Rated duration : 2 hr and others
- Mains supply : 230 Volts, 50/60Hz
- Power consumption : 2VA
- Battery : Maintenance-free sealed lead calcium battery  
(High temp nickel cadmium available)
- Charge monitor : Red LED ø5mm
- Test facility : Micro switch
- Safety feature : Low volt cut-off preventing battery overdischarge
- Fitting construction : Electro galvanised steel with epoxy powder coating  
The adjustable fire-retardant lamp-heads allow flexibility in angle of projection. Lamp heads comes with anti-glare lens
- Mounting : Wall
- Cable entry : ø20mm K/O hole
- Weight : 2.8kg (gross)
- Compliance : CP19, SS263 : Part 2, IEC 598-2-22
- Warranty : 1 year

### » Ordering Guide

Please check with Sales Dept if customisation is required

Model	Lamp (watt)	Battery type
MTL/NM/L203	2 x 3 LED	Sealed lead calcium
MTL/NM/L203 NC	2 x 3 LED	Nickel Cadmium

Specifications subject to changes without prior notice